

9800 Series

Off-Highway Series 9800

RATINGS

Straight-Thru Model		Gross Input Torque N•m (lb-ft)	Gross Input Power kW (hp)	Turbine Torque Net N•m (lb-ft)
S9805	Oil Field Pumping (Twin Installation)	6779 (5000)	1193 (1600)	9804 (6700)
S9806	Oil Field Pumping	7118 (5250)	1305 (1750)	9491 (7000)
S9820	Oil Field Pumping	8542 (6300)	1752 (2350)	10,235 (7550)

ENGINE INTERFACE

Acceptable full-load engine governed speed	1800 – 2100 rpm
Minimum engine idle speed range (with transmission in Drive)	550 rpm

MOUNTING

Direct	SAE No. 0 automatic flywheel housing with flexplate drive. Cradle mount using engine flywheel housing mounting pads and transmission rear cover mounting pads with 0.625-11 inch series bolts
Remote	Side pads on transmission rear cover plus front trunnion mount

TORQUE CONVERTER

Type Single stage, three element, polyphase.

Model	Stall Torque Ratio	Kp-Factor* at Stall
TC-1060	1.86	33.6 (39.1)
TC-1070	1.78	26.2 (30.5)
TC-1078	1.84	24.6 (28.6)
TC-1080	1.61	22.2 (25.8)

* Kp-Factor defines torque converter capacity. Kp = the ratio of converter pump speed [rpm] divided by the square root of the pump torque [N•m (lb-ft)]

MECHANICAL RATIOS (Gear ratios do not include torque converter multiplication)

Range	
First	3.75 : 1
Second	2.69 : 1
Third	2.20 : 1
Fourth	1.77 : 1
Fifth	1.58 : 1
Sixth	1.27 : 1
Seventh	1.00 : 1
Eighth	0.72 : 1
Reverse	Not Available

Ratio Coverage

Forward	5.21
---------	------

CONTROL SYSTEM

Description	Manual electric
-------------	-----------------

OPTIONAL ENGINE-DRIVEN POWER TAKE-OFF PROVISION

Side mount

Location	5 o'clock position, as viewed from rear	
PTO drive gear rating	Intermittent	59 tooth drive gear, 298 kW (400 hp)
	Continuous	59 tooth drive gear, 224 kW (300 hp)

Top Mount

Location	12 o'clock position, as viewed from rear	
PTO drive gear rating	Intermittent	59 tooth drive gear, 298 kW (400 hp)
	Continuous	59 tooth drive gear, 224 kW (300 hp)

ELECTRONIC SPEEDOMETER PROVISION

Description	Magnetic speed sensor, 41 pulses per output shaft revolution
Location	Output signal from transmission TCM

SIZE

Depth (below horizontal centerline)	530 mm (20.9 in)	
Length (direct mount) ^{2,3}	1411 mm (55.5 in)	
Width	892 mm (35.1 in)	
	Height	Dry Weight
Basic model	896 mm (35.3 in)	1678 kg (3700 lb)
With direct mount filters	1011 mm (39.8 in)	1678 kg (3700 lb)
With top engine-driven PTO drive gear		1692 kg (3730 lb)
With park brake (17.25 x 4 in)		1746 kg (3850 lb)
With remote mount		1714 kg (3780 lb)

OIL SYSTEM

Oil type	TES 439 (see www.allisontransmission.com for approved list)
Capacity excluding external circuits	79 litres (21.0 gallons)
Main circuit oil filter	
Standard	Manifold for full-flow, remote mounted, replaceable element
Optional	Direct-mount full-flow, replaceable elements (2)
Cooler circuit oil filter (optional)	Replaceable element, remote-mounted

1. PTO ratings apply to both top and side. Combined totals cannot exceed individual ratings. 2. For remote mounting, add 279 mm (11 in).
 3. Length is approximate from engine/converter mounting surface to face of typical output flange.

9000 Series

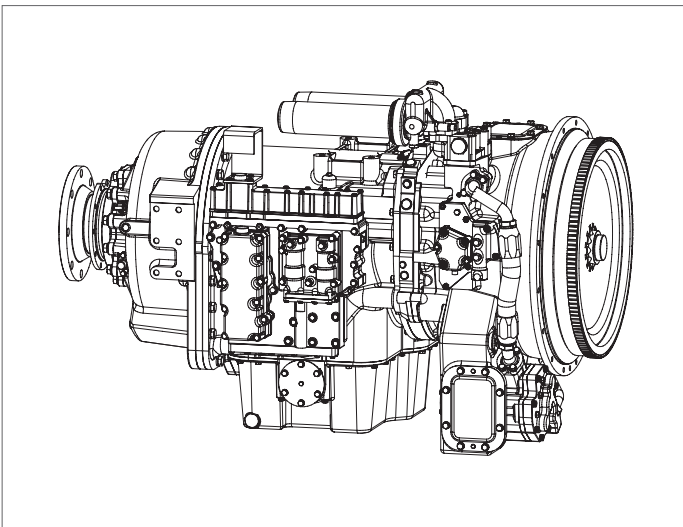

Information or specifications subject to change without notice or obligation.

